



## Printer Grounding, ESD Control and Output Symptoms

The Kodak 1200i printer consumes 1100 watts of power during typical operation and must be properly grounded in accordance with regional and general equipment/electrical grounding guidelines. Output quality problems including severe banding, ink overspray, abnormal printer calibrations, media transport problems (tiling accuracy), premature and intermittent cartridge jet failure, data shift, and personnel hazards may result if inadequate grounding is provided.

**CAUTION:** There is a serious safety issue when there is no earth ground connected to the printer. The printer will basically function but can cause a safety hazard if a person touches the printer chassis and another electrical device such as a computer. The voltage on the chassis can be raised to a level of approximately half the input AC voltage. The installer should always validate the power and grounding scheme at the installation facility. A second issue would be the lack of electrostatic discharge (ESD) protection. Without proper grounding the ESD brushes are rendered useless. A higher incidence of cartridge failures will occur if adequate grounding not properly supplied as well as possible malfunctions of printer's electronic circuitry. Review sections A – E:

### A. Symptoms of ESD/Electrical Interference

#### 1. Data Shift

Data shift problems are observed in printed output (i.e. problem appears in the horizontal direction, projecting from either the left and/or right sides of printed image). The data shift may also appear through the center of the image as the second picture illustrates.

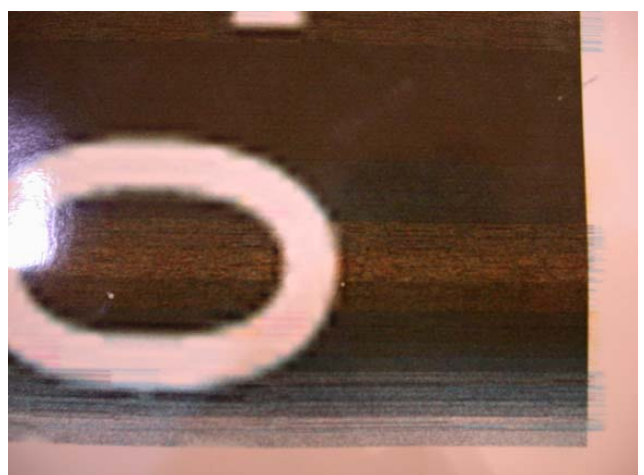

**NOTE:** Electrostatic discharge (ESD) is a special type of transient impulse. ESD refers to the abrupt release of charge that has accumulated on a person or object. This charge can result in voltages above 15,000 volts. A direct ESD spark can cause component failures or malfunction. Poor grounding and low humidity combined typically cause higher levels of media ESD discharge.

**2. Ink Overspray**

Ink Overspray and/or combination of data shift and ink overspray is observed. Normally occurs at severe ground fault locations (high levels of AC riding on ground/neutral lines or high levels of ESD are coming from the air plenum). Refer to B. below.

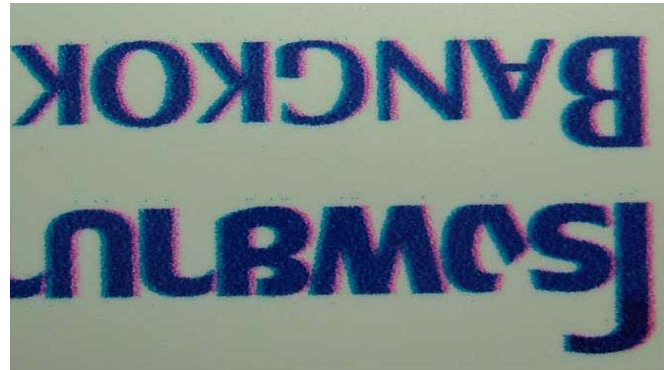

**3. Media Static Cling (Feed Transport Problems/Tiling Problems)**

- Color calibration horizontal lines (i.e. Color Cal Vertical pattern) are incorrectly spaced (i.e. two lines are closer together while one line is spread farther from the other two) or may be printed outside of the calibration box area.

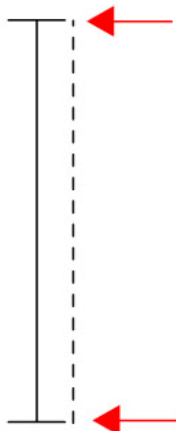

- Feed adjust values may be too low (i.e. 4840 to 4870). Typical feed adjust (paper calib values) should be 4800 +/- 15 for most media types. Media which generates a high amount of static electricity (i.e. 15,000~30,000 volts) and is thin (i.e. 3 mil) may be subject to improper transfer through the printer's media path.



**NOTE:** To isolate a suspected media type, load a different the media type (i.e. rapid dry or coated matte print paper) and run the line length test and color calibration pattern again. Print a 1 yard (1 meter) panel to evaluate printer performance.

**4. Intermittent Banding/Improper Print**

- Static discharge build-up combined with poor building grounding can cause excessive ESD discharge, from the media as it unwinds, during long plots. This will depend on the media type and media transport rate through the printer.



**NOTE:** The addition of a humidifier in the room/print area has been found to help correct these types of problems in many cases.

**5. Premature Cartridge Failure <700 ml**

Massive cartridge jet failures may occur prior to the standard cartridge warranty (700 ml). Static interference and electrical discharges from media/printer to the cartridge jet plates can cause premature failure of internal cartridge electronics (i.e. Poly Poster, Polyethylene, Lumatrans, Duratrans or similar 'plastic' media is known to release ESD charges during media feed).

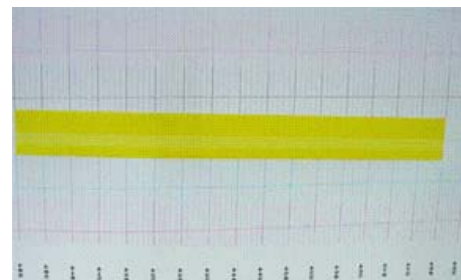

**B. ESD Control Measures**

**1. Proper Power Cord & Grounding**

- Only use the approved power cord, for the specific region, as supplied with the printer. The third prong (ground line) is required for proper printer operations, personnel safety and circuit protection. Only attach power cord to a 3-prong grounded electrical receptacle (refer to section C below).



## 2. Humidifiers

- The addition of a humidifier can solve print output problems where relative humidity (Rh) is too low (i.e. <30% Rh) and/or when mild grounding problems exist. The addition of a humidifier can reduce the effects of ESD on printed output. If the humidity in the printing area is increased and the above symptoms disappear then a grounding issue/ESD problem is likely present, but not severe. If the addition of a humidifier solves the problem permanently then no further action may be necessary unless premature cartridge failures occur.



**NOTE:** Even with adequate grounding measures intact, relative humidity should typically be between 45% and 55% in a normal room temperature environment for the best printing results (ESD suppression and color control). The suggested temperature range is 68-72 degree F. (20-22.2 degrees C.)

## 3. Ant-Static Mats

- The installation of Anti-Static mats below the printer have been known to help control ESD levels between personnel and the printer.



Sample vendor website:

<http://www.anti-staticmat.com/ESDAntiFatigueFloorMatDirectory.htm>

## C. Printer/Receptacle Power Tests

If the ESD Control Measures (above) have been installed and ESD symptoms continue to exist with printer operation it is suggested to check for proper printer/receptacle power and adequate grounding. Below are some suggested test methods for both the printer and the incoming power source.

### CAUTION

**Only properly trained service technicians should attempt to perform Step 1 below. It is strongly suggested to contact a certified electrician if a test method or measured value is not completely understood.**

#### 1. Testing AC level on printer chassis:

- Turn on Printer. With meter in an AC scale, connect both the black and red leads to the printer's rear metal plate screws at rear of printer. The normal chassis AC voltage reading, with proper electrical wiring/grounding in place, should be between 0.0 and 0.4 volts AC. Any level higher than 2 volts AC indicates a ground or neutral line problem is present (ground fault or floating ground).

**NOTE:** Typically anything below 4.5 volts AC will not cause a problem with printed output, but this largely depends on humidity level and ESD level of media. Values



higher than 8.0 volts AC will start to cause some problems with image output (refer to section A); values greater than 12.0 volts lead to more severe problems including premature cartridge failures and severe banding.

#### 2. Verify Proper Receptacle Configuration:

Verify the regional power (source) receptacle has a Ground (G) line for the respective region (N is neutral; L is line or hot).

**CAUTION:** If receptacle does not have a ground line (2-prong outlet only) then immediately stop using the printer. The printer is extremely dangerous to operate in this configuration (with power applied) and is a personnel hazard. The problem, for the symptoms described in section A, cannot be fully corrected until the electrical system/receptacle is properly fixed. Inform the customer a certified electrician will need to be contacted to upgrade the electrical system with a properly grounded outlet.

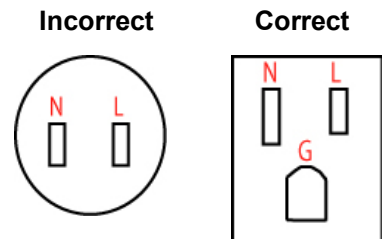

**CAUTION**



Do not operate/work on printer if a 3-prong to 2-prong adapter, non-grounded standard receptacle, non-grounded GFCI receptacle, or a 'separate' ground line runs from the printer. Contact technical support management if necessary for intervention/assistance.

**3. Testing Receptacle Neutral-to-Ground Voltage:**

- In North America the easiest and safest test method is to use a receptacle tester (i.e. available at Home Depot) to determine proper outlet polarity and grounding. Simply plug the device into the outlet (standard and GFCI outlets), typically two LEDs (of the same color) should illuminate indicating proper electrical configuration.
- In all other countries a voltmeter may be used for test purposes. Verify the voltage level between Ground and Neutral is correct (normally <2.0 volts AC). A 'voltage screwdriver' may be used to easily test for the presence of voltage (phase) on ground and neutral lines (LED illuminates).



**NOTE:** neutral and line may be reversed in many European countries.

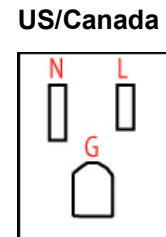
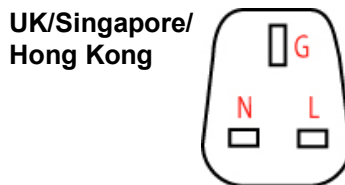
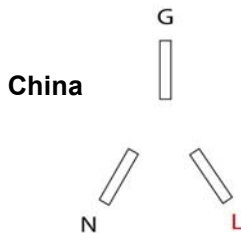

**CAUTION**

If neutral-to-ground voltage, above 6 volts AC, is present then a serious problem is present within the building's electrical system. Often a mis-wired connection or imbalanced phase load can cause voltage/current to 'bleed' onto the ground line (commonly referred to as neutral-to-ground voltage) or a serious ground fault exists within the building. Immediately stop operations/service on the printer. The printer is extremely dangerous to work on in this condition



(with power applied) and is a personnel hazard. The problem, for the symptoms described in section A, cannot be fully diagnosed and/or corrected until the electrical system/receptacle is properly fixed. A certified electrician will need to be contacted to upgrade the electrical system with a properly grounded outlet or to correct a neutral-to-ground voltage problem.

#### **D. Power/Voltage Testers**

1. In North America, basic receptacle testers are available for testing standard 110 volt receptacle/wall outlets for proper polarity and ground detection. These models are probably the fastest and safest way in detecting improper wiring or the presence of a ground fault.



The three LEDs help the electrician or technician identify:

- Correct wiring
- Hot/neutral reverse
- Hot/ground reverse
- Missing neutral
- Missing ground
- Missing hot.

2. In other continents a simple voltage 'screwdriver' may be used, such as the inexpensive Stanley 3MM Voltage Tester. These tools are used to determine the presence of phase on a hot line (L), neutral (N) or even ground (G).



3. The universal test instrument is the voltmeter or multimeter which may be used to measure dc, ac, resistance, etc.



## **E. Common Mistakes by Customers/Technicians**

1. The printer should only be grounded to the buildings electrical receptacle/outlet using the power cable provided and should conform to all electrical building grounding regulations in accordance with country/regional regulations. If a printer grounding problem is discovered only have a certified electrician ground the power source receptacle properly.

### **CAUTION**

Do not implement any of the following actions listed below or personnel hazards and/or equipment damage may result:

#### **a) Secondary Grounding**

- If the receptacle or power strip is grounded (or thought to be grounded) do not attach a secondary ground to printer under any circumstances. This can be dangerous to the operator and/or equipment. Introduction of a 'ground loop' into the equipment can cause different problems/symptoms to suddenly appear and can be dangerous to the operator.

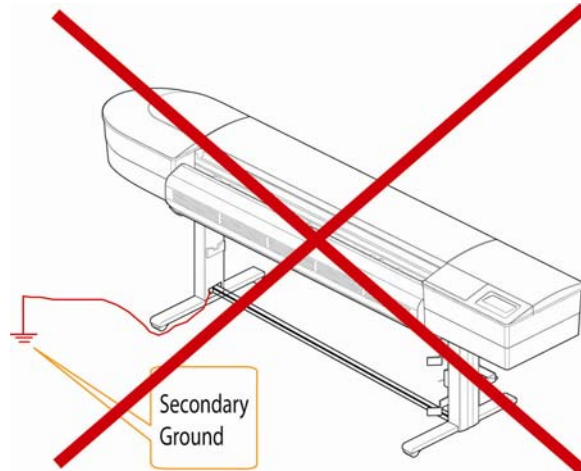

#### **What is ground loop?**

A ground loop occurs when there is more than one ground connection path between two pieces of equipment. The duplicate ground paths form the equivalent of a loop antenna which very efficiently picks up interference currents. Lead resistance transforms these currents into voltage fluctuations. As a consequence of ground-loop induced voltages, the ground reference in the system is no longer a stable potential, so signals ride on the noise. The noise becomes part of the program signal.

Ground loop is a common wiring condition where a ground current may take more than one path to return to the grounding electrode at the service panel. AC powered computers all connected to each other through the ground wire in common building wiring. Computers may also be connected by data communications cables. Computers are therefore frequently connected to each other through more than one path. When a multi-path connection between computer circuits exists, the resulting arrangement is known as a "ground loop". Whenever a ground loop exists, there is a potential for damage from intersystem ground noise. The ground loop theory also applies for printers connected to these same computers, but the primary difference is computers do not pull anywhere near the wattage demands of the printer.

While lower currents may cause a slight audible hum on signal lines (typically in video/audio electronics), higher currents can cause more serious problems such as sparking in connections (Ethernet port), damage to circuit assemblies signal wiring. Only perform printer installations using the recommended guidelines and ensure a proper printer ground is present.

**b) 3-Prong to 2-Prong Adapters**

- Do not attach a 3-prong adapter to a 2-prong or non-grounded electrical outlet just for the purpose of supplying power to the printer – call an electrician immediately and correct the power source problem. Bypassing the ground connection enables a free floating ground to exist at the printer which is not only dangerous to the operator but will likely result in imaging output problems.

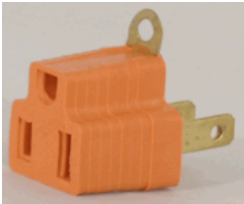

i.e. Some technicians install line adapters which have a ground lead, then attach a wire between the ground lead and the receptacle box housing (i.e. screw) or other fixed point.

**CAUTION**

Installation of these types of adapters provides an extremely unreliable ground, is dangerous to the operator and equipment, and should never be considered a solution.

**c) Non-Grounded Conditioners/Regulators**

- Never connect a line conditioner or power regulator to an ungrounded power source – this can be dangerous to the equipment and operator. See b. above.



## **F. Related Print Symptoms**

If data shift is observed at image edges combined with an 'image shift' then this problem is typically a dirty encoder strip or dirty encoder sensor and not a printer ESD or grounding problem. Please refer to Technical Bulletin 3 for proper cleaning procedures.



### **DISCLAIMER:**

This technical bulletin has been provided as an aid to assist the customer/technician/authorized service provider, or electrician in solving a very specific issue regarding grounding related problems on the Kodak 1200i printer as detailed above. This document is not intended to assist with other electrical or equipment issues, nor does it supersede any regional electrical code regulations or ordinances. For grounding related problems on the printer it is strongly suggested for the customer to consult a regionally certified electrician for advice/assistance.